

I.O.M. #090 7/10

INSTRUCTION MANUAL • INSTALLATION • OPERATION • MAINTENANCE

D1 Series

PACKAGE CHILLER

®

Covering Air-Cooled Models
from 1 to 10 tons with
M1 Chiller Control Instrument



ADVANTAGE ENGINEERING, INC.
525 East Stop 18 Road Greenwood, IN 46142
317-887-0729 fax: 317-881-1277
Service Department fax: 317-885-8683
www.AdvantageEngineering.com
e-mail: service@AdvantageEngineering.com

D1 Series

PACKAGE CHILLER

®

INSTRUCTION MANUAL

for D1 Series

1 - 10 Tons

Air-Cooled Package Chillers

COVERING

**INSTALLATION
OPERATION
MAINTENANCE**



ADVANTAGE ENGINEERING, INC. 525 East Stop 18 Road Greenwood, IN 46142
317-887-0729 fax: 317-881-1277 Service Department fax: 317-885-8683
website: www.AdvantageEngineering.com e-mail: service@AdvantageEngineering.com

TABLE OF CONTENTS

1.0	GENERAL	7
1.1	Unit location	8
1.2	Efficiency	8
1.3	Safety	8
1.4	Clean air act	9
1.5	Miscellaneous	9
1.6	Water Treatment	
1.7	Components	10
2.0	INSTALLATION	11
2.1	General	12
2.2	Unit location	12
2.3	To and from process connections	12
2.4	Manual fill port	13
2.5	Electrical connection	13
3.0	OPERATIONS	17
3.1	General	18
3.2	Start up/operations procedure	19
3.3	Instrument/operation	23
3.4	Shut down procedure	28
4.0	TROUBLESHOOTING	29
4.1	Unit will not start	30
4.2	Compressor hums but will not start	30
4.3	Shuts off on high pressure control	30
4.4	Shuts off on low pressure control	31
4.5	Compressor shuts off on internal overload	31
4.6	Low or now process pressure or water flow	31
4.7	Cooling capacity inadequate	32
4.8	Sensor	32
4.9	Pumps	32
4.10	Crankcase heater	33
4.11	M1 Chiller Instrument	33
5.0	MAINTENANCE	35
5.1	Warranty service procedure	36
5.2	Periodic preventative maintenance	36
5.3	Special maintenance	37
5.5	Pump seal service	38
5.6	Checking the refrigerant charge	41
5.7	Proper cleaning procedure for brazed plate evaporators	42

6.0	COMPONENTS	45
6.1	Water system	46
6.2	Refrigeration system	46
7.0	APPENDIX	49
7.1	Operations below 48°F fluid or 38°F ambient	50
7.2	Inhibited propylene glycol	51
7.3	Water quality control	51
7.4	Sensor current vs temperature	52
7.5	Refrigerant Pressure - Temperature Chart	53
7.6	Chiller capacity and derate chart	54
7.7	Air-Cooled Schematic	55

THIS PAGE INTENTIONALLY BLANK

1.0 GENERAL

- 1.1 UNIT LOCATION
- 1.2 EFFICIENCY
- 1.3 SAFETY
- 1.4 CLEAN AIR ACT
- 1.5 MISCELLANEOUS
- 1.6 WATER TREATMENT
- 1.7 COMPONENTS



1.1 UNIT LOCATION

- A. The chiller is designed for outdoor or indoor use. For most efficient operation, locate the chiller in a clean and well ventilated environment.
- B. If the chiller is installed in an environment where ambient temperatures could consistently be under 40°F, a glycol and water solution must be used instead of plain water.
- C. The air-cooled chiller has an air-cooled refrigerant condenser. A motor driven fan generates air flow through the condenser to remove heat from the refrigerant system. The air-cooled condenser on the portable chiller will discharge a maximum of 15,000 BTU's per hour per ton of cooling.
- D. The air-cooled chiller must have a minimum entering air temperature of 0°F and a maximum entering air temperature of 95°F for efficient operation.
- E. The air-cooled chiller must have a minimum of 4' clearance at the air intake and six feet at the exhaust air discharge.
- F. If the operator has any questions concerning the location and operation of the air-cooled portable chiller, contact the Advantage Engineering Service Department at 317-887-0729.

1.2 EFFICIENCY

- A. Long term efficiency of operation is largely determined by proper maintenance of the mechanical parts of the unit and the water quality. Advantage recommends filtering (recommended to 300 micron, 50 mesh) where required to prevent solids from plugging critical parts (pumps, evaporators, seals for example). Advantage highly recommends the services of a competent water treatment specialist be obtained and their recommendations followed.

Advantage accepts no responsibility for inefficient operation, or damage caused by foreign materials or failure to use adequate water treatment.

1.3 SAFETY

- A. It is important to become thoroughly familiar with this manual and the operating characteristics of the chiller.
- B. It is the owner's responsibility to assure proper operator training, installation, operation, and maintenance of the chiller.



- C. Observe all warning and safety placards applied to the chiller. Failure to observe all warnings can result in serious injury or death to the operator and severe mechanical damage to the unit.

1.4 CLEAN AIR ACT

- A. The chiller contains HCFC-22 (chlorodifluoromethane). This is a class 2 substance.
- B. Effective July 1, 1992, it is unlawful for any person in the course of maintaining, servicing, repairing, or disposing of refrigeration equipment to knowingly vent or otherwise dispose of any class 2 substance used as a refrigerant in the manner which permits such substance to enter the atmosphere.
- C. De minimis releases associated with good faith attempts to recapture, reclaim or recycle such substance shall not be subject to the prohibition set forth in the preceding paragraph.

1.5 MISCELLANEOUS

- A. The chiller is designed to circulate temperature stabilized fluid through the process resulting in process temperature control.
- B. The ability of the chiller to maintain process temperature control is significantly affected by the method of installation.
- C. If the operator has any questions concerning the location and operation of the chiller, contact the Advantage service department at 317-887-0729.

1.6 WATER TREATMENT

- A. The use of untreated or improperly treated water in a package chilling system may result in scaling, erosion, corrosion, algae or slime.
- B. It is recommended that the services of a qualified water treatment specialist be engaged to determine what water treatment is required.
- C. Advantage assumes no responsibility for equipment failures which result from untreated or improperly treated water.

1.7 COMPONENTS

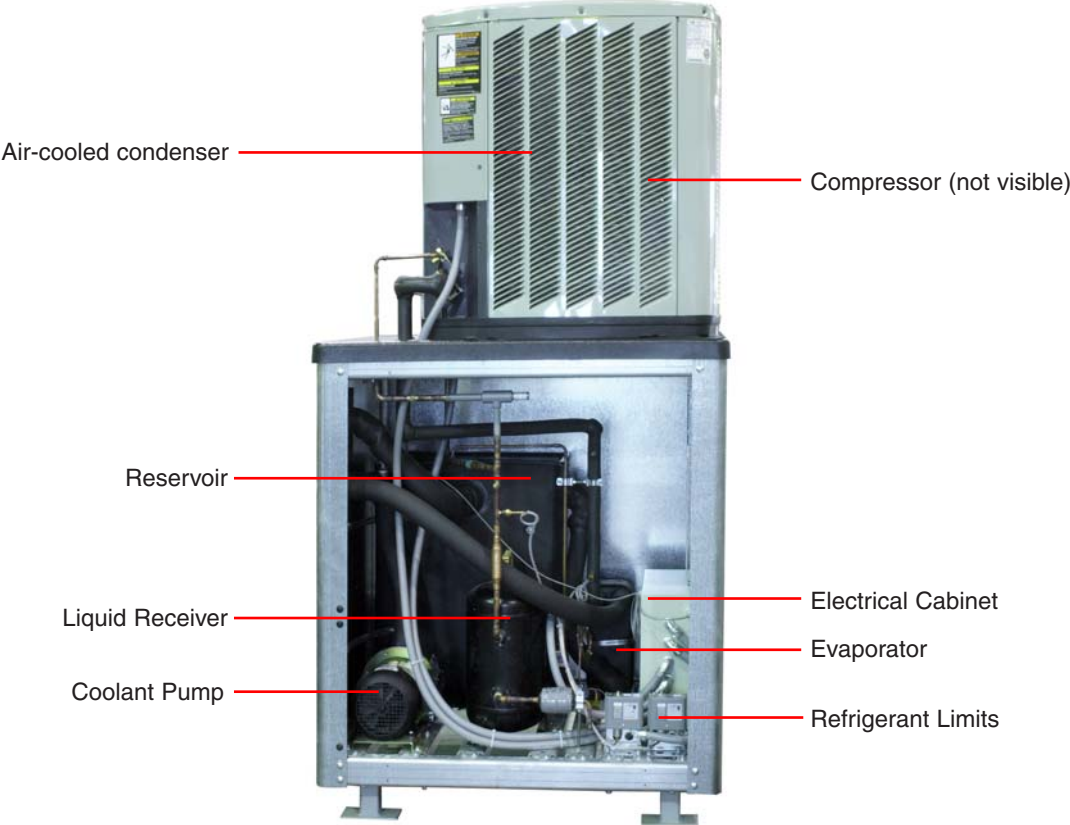

5 ton unit shown. Other tonnage have similar orientation.

2.0 INSTALLATION

- 2.1** GENERAL
- 2.2** UNIT LOCATION
- 2.3** TO AND FROM PROCESS CONNECTIONS
- 2.4** MANUAL FILL PORT
- 2.5** ELECTRICAL CONNECTION



2.1 GENERAL

- A. All process piping materials (such as hose, rigid piping, valves or filters) used in process water piping circuitry must be rated for 100°F minimum temperature and 100 PSI minimum pressure.
- B. All such materials must have the equivalent or larger diameter of the particular process connection that length of process water piping is connected to.

2.2 UNIT LOCATION

- A. Air cooled condensers require ambient air temperatures between 0°F and 95°F for efficient operation. Operating above 95°F may result in elevated condensing pressures and eventual shut-down on the high pressure safety switch. Air temperatures below 60°F may result in below normal condensing pressures and poor condensing.
- B. Air flow is generated by the motor driven fan located inside the condensing unit. Air flow is from the outside of the chiller, through the condenser and exhausted through the top of the unit.
- C. A free air space of at least four (4) feet is required at the condenser intake and six (6) feet at the condenser discharge to allow for proper air flow.
- D. At full load, the chiller will discharge approximately 15,000 BTU's per hour per ton of cooling.

2.3 TO AND FROM PROCESS CONNECTIONS

- A. Connect the '**TO PROCESS**' port to the water supply piping.
- B. Connect the '**FROM PROCESS**' port to the return water piping.
- C. Process water piping circuitry should be designed to avoid an excessive use of elbows and/or lengths of pipe or hose. If hose is the material of choice, avoid tight twists or curls and excessive lengths.
- D. Valves and filters may be installed in the process water piping circuitry to facilitate service and maintenance provided that such devices maintain the full inside diameter of the process connection. If installed, all such devices must be open and clean during unit operation.



2.3 MANUAL FILL PORT

- A. Use the Manual Fill port to fill the unit's reservoir and the process.
1. Connect the unit's 'manual fill' port to the plant's city water source.
 2. Minimum water supply pressure requirement is identified on the equipment data plate. This is normally 20 psi.
 3. Be certain to use a water supply line equipped with a back flow prevention device to prevent contamination of potable water.

2.4 ELECTRICAL CONNECTION

- A. Electrical power supply requirements are identified on the equipment data tag. Determine the plant's voltage supply is the same as the unit's voltage requirements.

WARNING: Do not connect the unit to a voltage supply not equal to the unit's voltage requirements as specified on the unit's data plate. Use of incorrect voltage will void the unit's warranty and cause a significant hazard that may result in serious personal injury and unit damage.

- B.** A customer supplied, four conductor cable is required for connection to a customer supplied fused disconnecting means. The fused disconnecting means shall be sized and installed according to the unit's power supply requirements and local electrical codes.
- C.** Connect the four conductor power cable to power entry terminal block on the unit's electrical panel. Then connect the power cable to the customer supplied fused disconnect switch.
- D.** The unit's supplied control circuit is 110 volt, 1 phase, 60 cycle. The control circuit is supplied by the factory installed transformer. An inline control circuit fuse is provided.

E. GENERAL

- 1. Make certain all ground connections to the unit are properly affixed.
- 2. Make certain power conductor, disconnecting means, and fusing are properly sized according to the unit's power supply requirements.
- 3. Make certain all electrical connections are tightly affixed. Any loose wiring connections must be tighten before engaging the power supply.
- 4. Make certain no moisture or standing water is present inside the electrical cabinet.

F. INFORMATION REGARDING 'PHASING' OF SCROLL COMPRESSORS

- 1. All chillers that have pumps, the compressor(s) will be set in phase with the pump during the testing process at the factory.
- 2. After installation, the phase status must be checked by observing the pump motor shaft on the end of the pump and comparing its rotation to the directional arrow on the motor. In either case, if the phase needs to be altered, it should be done at the main power entry.

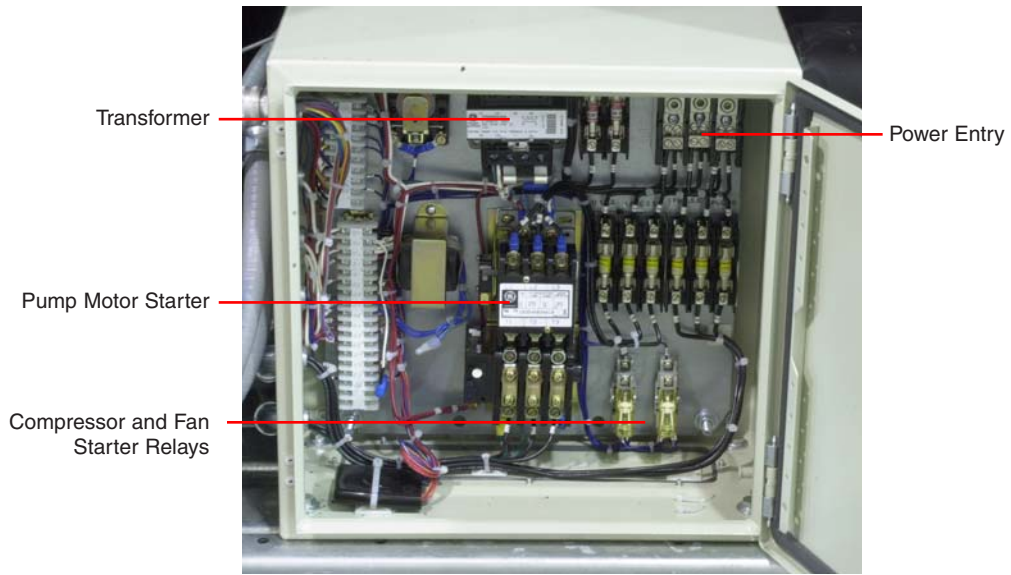

Electrical Cabinet

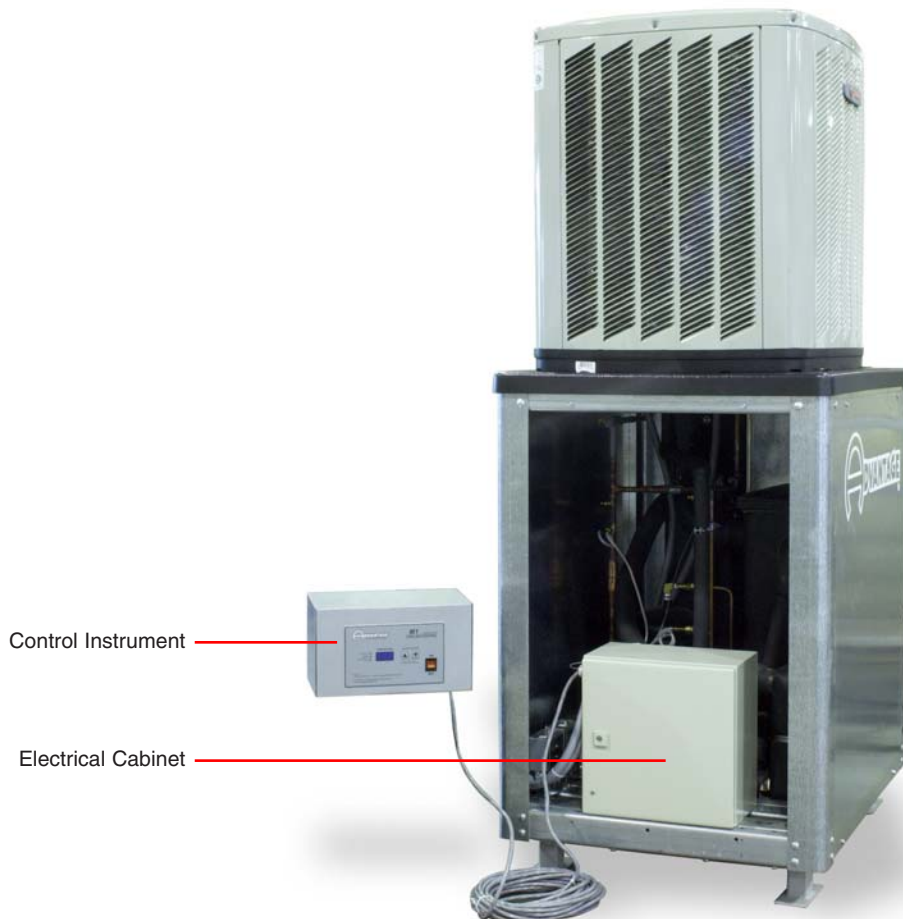

Front panel removed for photo.

THIS PAGE INTENTIONALLY BLANK

3.0 OPERATIONS

- 3.1 GENERAL**
- 3.2 START UP/OPERATIONS PROCEDURE**
- 3.3 INSTRUMENT/OPERATION**
- 3.4 SHUT DOWN**



3.1 GENERAL

- A. Failure to follow the factory required operations procedure may adversely affect the unit's ability to adequately control process temperature and may create a hazardous operating condition which may result in serious operator injury and/or unit damage.

- B. **IMPORTANT:** if this unit contains a hermetic or semi-hermetic reciprocating compressor it is equipped with a crankcase heater on the compressor. While the compressor is idle, the crankcase heater prevents freon vapor from migrating to and condensing in the compressor crankcase. If freon is allowed to condense in the crankcase, it can be drawn into the cylinders upon start up. This can cause catastrophic damage to the connecting rods, pistons, and valve plates.

To avoid this, **BEFORE THE UNIT IS STARTED, THE POWER SUPPLY SHOULD BE APPLIED TO THE UNIT FOR AT LEAST 12 HOURS, OR UNTIL THE BOTTOM OF THE COMPRESSOR IS WARM TO THE TOUCH.**

If the power has been disconnected more than two hours, the power should be applied for six hours before restarting. Power should be applied to the unit continuously, except for service purposes. The crankcase heater should be checked for proper operation on a regular basis.

UNITS WITH SCROLL COMPRESSORS DO NOT HAVE A CRANKCASE HEATER AND THIS PROCEDURE IS NOT NECESSARY.

- C. The OPERATIONS segment of this manual is divided into the following sections:
 - 3.2 **Start up/operations** - follow this segment to start the unit after the initial install to the process system or to restart the unit after reinstallation to the same or different process system. This section includes information on system fill, electric motor phasing (pump rotation) and process flow adjustments.

 - 3.3 **Instrument** - follow this segment to start up and operate the instrument. This section includes information on setpoint selection and adjustment, and feature explanations.

 - 3.4 **Shut down procedure** - follow this segment to shut down the unit. This segment includes information on system shut down, electrical power supply precautions, and disconnection from system.

3.2 START UP / OPERATION PROCEDURE

A. SYSTEM FILL

1. The unit has an internal reservoir which must be filled and maintained for proper operation. The unit has a sight glass to monitor the proper water level in the reservoir.
2. **WATER QUALITY CONTROL.** Lack of, as well as, improper water treatment can damage the chilling unit. The services of competent water treatment specialist should be obtained and their recommendations followed. It is the equipment owner's responsibility to prevent damage from foreign material or inadequate water treatment. See water treatment section elsewhere in this manual for more information.

3. **MANUAL FILL:** disconnect the electrical power supply. Use the external fill port or remove all necessary cover panels to access the reservoir to add fluid directly to the reservoir. When the pump is first started, as process lines are filled and air is purged, additional fluid may be required to restore the reservoir to the correct level. Verify reservoir level via the coolant sight glass (figure 3.2A).



Typical reservoir sight glass Figure 3.2A

B. ELECTRIC MOTOR PHASING (PUMP ROTATION)

1. The operator must determine that the unit is phased correctly by visually inspecting the rotation of the pump motor shaft. The procedure is outlined below. Incorrect phasing results in poor operation and eventual damage to the unit.
 - a. Supply electrical power to the unit. Once the correct voltage is supplied to the unit, the POWER switch on the unit's control panel will illuminate. Adjust the setpoint above the tank water temperature to prevent the compressor from activating during this procedure.
 - b. Remove all necessary cover panels to access the pump motor. **Note that the electrical power is engaged at this point and caution must be observed while the electrical supply is engaged**

and cabinet panels are removed and opened.

- c. Locate the electric motor (figure 3.2B). The electric motor can be identified when the electrical panel cover is open. The operator must identify the motor shaft inside the electric motor housing. The motor shaft can be seen through the vent slots in the motor housing or by removing the shaft cover.

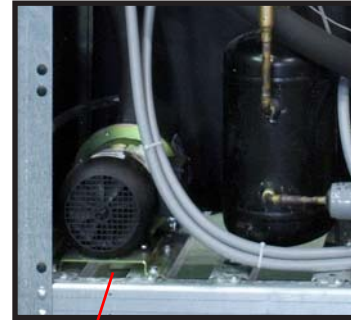

Electric motor

Figure 3.2B

- d. Toggle the illuminated ON/OFF SWITCH (figure 3.2C). This will quickly cycle the pump motor “on” and then “off”.

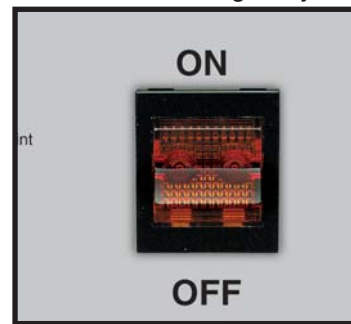

On/Off switch

Figure 3.2C

- e. Observe the motor shaft. When the ON/OFF SWITCH is on, the motor shaft will rotate. When switched off, the shaft will slowly “coast” to a stop. As the shaft slows, the operator can identify the rotation of the motor shaft. Correct rotation (correct phase) is “clockwise”, when viewed from the rear of the motor. Incorrect rotation is “counter-clockwise” (incorrect phase) when viewed from the rear of the motor. If the shaft does not rotate when the ON/OFF SWITCH is on, the operator must identify the cause as outlined in the troubleshooting and repair section of this manual.
- f. If the motor shaft is phased correctly (shaft turns in a clockwise direction), continue with **step C**. If the motor shaft is **NOT** phased correctly (shaft turns in a counter-clockwise direction), correct as outlined in **step 2**.

2. If the unit is phased **incorrectly**, the operator must:

- a. Disengage the electrical power supply to the unit at the unit’s disconnect switch. Follow proper lockout procedures before proceeding.

- b. Once the electrical power supply is disengaged, reverse any two power leads of the power cord at the disconnect terminals.
- c. **Note:** reversing any two power leads of the power cord will correctly phase the power supply to the unit. **The operator must reverse the power leads at the disconnect switch only and not at the power entry terminals on the unit's electrical panel.** The unit's internal electrical system wiring is phased correctly at the factory and must not be altered in the field.

C. PROCESS FLOW ADJUSTMENTS

1. The operator must determine and set proper water flow rate for the most efficient and trouble free operation.
 - a. Water flow rate through the process is determined by the pressure losses in the process loop. Generally, higher flow rates result in turbulent flow achieving maximum temperature control and lower maintenance. Since the evaporator in most liquid chillers is flow sensitive, the efficiency of operation is directly related to the flow of liquid.
 - b. Maximum chiller efficiency is obtained at approximately 2.4 gpm per ton of rated capacity. Low liquid flow can reduce efficiency and in some cases allow ice to develop in the evaporator which can damage the evaporator. Excessive liquid flow will trip the motor overload protection circuit.
2. Switch on the illuminated ON/OFF SWITCH to activate the process pump. Wait a few moments to allow air to be purge from system. Observe the COOLANT pressure gauge for steady readout. Two items that the operator must check for are *low flow* and *excessive flow* conditions.
3. **LOW FLOW:** If a low flow condition is present, be sure all process valves are open. If all process valves are open and a low flow conditions exists, consider the following:
 - a. To operate under a low flow condition, it is necessary to install a flow bypass system in the process circuitry. This will allow a portion of the flow to bypass the process and return directly to the chiller. This keeps the total flow above the cutoff point. Figure 3.2D illustrates a typical bypass loop.
 - b. Some models may have a factory installed bypass. Adjust the valve accordingly.

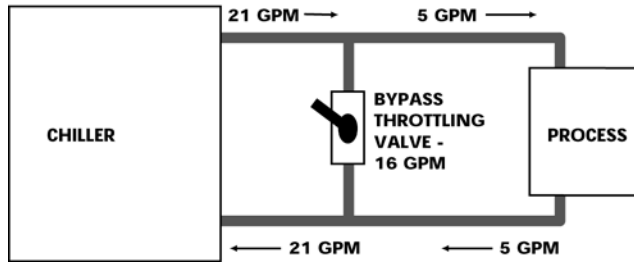
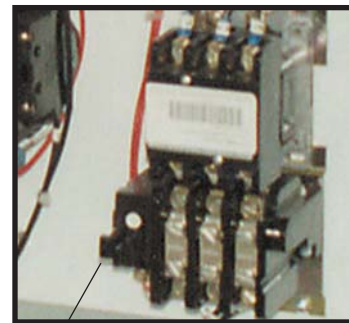

Figure 3.2D Typical low flow by-pass loop

4. **EXCESSIVE FLOW:** if the flow rate exceeds the motor HP capacity, the electric motor will draw excessive amps. This is a result of the process loop's ability to flow water at a greater rate than can be provided by the pump. This eventually results in tripping the thermal motor overload relay (overload relays open) and the unit will shut down.

- a. If an excessive flow situation is encountered and the motor overload circuit has tripped, the operator must manually reset the overload relay (figure 3.2E) before operations can continue.



Reset level on overload relay Figure 3.2E

- b. This is done by opening the electrical panel cover, identifying the reset lever on the overload relay, and pushing the reset lever "in" until the overloads are reset (evidenced by a "clicking" sound as the overloads reset).
5. Set the process flow rate by measuring the pump motor amperage and adjusting the process flow rate via the motor amperage:
 - a. Open electrical cabinet panel door. **Note that the electrical power is engaged at this point and caution must be observed while the cabinet panel is open.**
 - b. Identify the motor starter block. This block consists of the motor starter contactor and the overload relay.
 - c. Place an amp meter on a single power lead emanating from the overload relay.
 - d. Identify the electric pump motor. Locate the name

plate on the motor housing (figure 3.2G). The full load amp rating for the motor is listed on the name plate.

- e. Engage the electrical power supply and start the pump motor by pressing on the illuminated ON/OFF switch on the display.

- f. The amp meter will display the motor amps. Compare the actual motor amps as displayed on the amp meter to the full load amp rating as listed on the motor name plate.



Motor Data Plate

Figure 3.2G

- g. If the amp draw is excessive (higher than the listed name plate amp rating), a throttling valve must be installed in the “from process” circuit line. The preferred throttling valve is a manual activated ball valve. If necessary, follow proper shut down and disconnect procedures to install a throttling valve.

- h. With the throttling valve installed, fully close the valve and then engage the pump. Slowly open the throttling valve and monitor the motor amps as displayed on the amp meter until the actual motor amps equals the listed full load amp rating of the motor. The process flow is now correctly adjusted.

3.3 INSTRUMENT/OPERATION

A. GENERAL

1. The M1 chiller instrument comes housed in a removable enclosure with 50' or remote cable (figure 3.3A).
2. Route the remote cable through the cabinet and isolate from other low and high voltage wiring.
3. Consult the factory when extended cable lengths are required.



Chiller instrument as shipped from the factory.

Figure 3.3A



Remote instrument cable properly routed through the cabinet.

Figure 3.3B

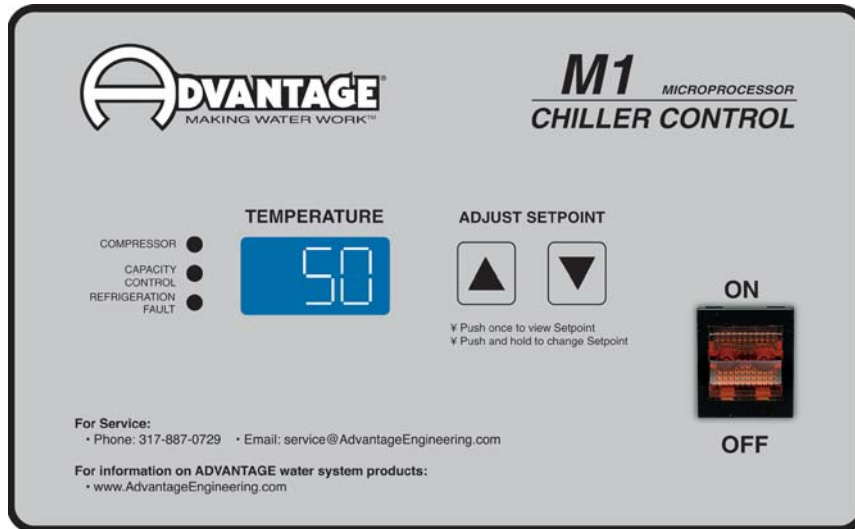

Instrument display

Figure 3.3C

B. INSTRUMENT START-UP

1. When the correct electrical power is supplied, the tank is adequately filled and the water flow rate is properly adjusted, it is possible to start the unit.
2. Upon power up, the instrument displays “ChF” indicating that the unit is in Fahrenheit temperature mode or “ChC” indicating that it is in Celsius mode. The control then shows the current setpoint for approximately 2 seconds before reverting to the To Process temperature. When power is supplied to the unit, the ON/OFF switch will illuminate.

3. Precautions:

The chiller control is programmed from the factory with a setpoint range of 48° to 90°F. To operate below 48°F or if the ambient conditions where the chiller is installed will reach temperature below 35°F, the addition of inhibited propylene glycol is required.

If a setpoint of 48°F or less is required, then additional modification of the limit switch setting is also required. Diligent monitoring of the water/glycol solution is mandatory to prevent freezing of the evaporator. Freezing may cause the evaporator to rupture allowing water and freon to mix which will cause major damage to the refrigeration system.

Operating above 70°F requires the addition of a refrigerant crankcase pressure regulating (CPR) valve. The CPR valve is necessary to prevent overloading of the compressor and to reduce return gas temperatures that cool the compressor windings which can cause premature failure.

Contact your local refrigeration contractor or the factory for further information about the proper use of inhibited propylene glycol and modification of limit switches.

4. After selecting a set point temperature, the operator may leave the display in the SET POINT state. The display will automatically return to the TO PROCESS temperature state after thirty seconds. If the operator leaves the display in any state other than the TO PROCESS state, the display will automatically revert after 30 seconds of inactivity.

B. INSTRUMENT OPERATION

1. **To start the unit, toggle on the illuminated ON/OFF SWITCH.** The chiller control will begin temperature control operations.
2. To select setpoint temperature, press and hold the UP ARROW or DOWN ARROW keys until the desired set point temperature is displayed in the TEMPERATURE WINDOW. The default range for the setpoint temperature is 48° - 90°F or 9° - 32°C.
3. The setpoint temperature can be displayed by pressing the UP ARROW or DOWN ARROW keys. The setpoint temperature will be displayed for 5 seconds.
4. When the compressor is turned off, the instrument will wait 3 minutes before turning it back on regardless of the To Process temperature or setpoint. If a fault has occurred, the

control will attempt to turn the compressor on after 3 minutes powered down. If the fault condition remains, the control will turn the compressor off and retry after 1 minute. This sequence will repeat until the compressor turns on or instrument power is cycled.

5. Under normal conditions (no fault conditions, compressor has been off for three minutes) the instrument will turn on the compressor when the To Process temperature is above the setpoint. The instrument will turn on the hot gas bypass when the To Process temperature is below the setpoint by no more than 3 degrees.

The instrument will turn off the compressor and hot gas bypass when the To Process temperature is 4 degrees or more below the setpoint.

C. INSTRUMENT CONTROLS

1. **ILLUMINATED ON/OFF SWITCH:** this rocker switch starts or stops the unit. Electrical power is supplied to the unit when the switch is illuminated.
2. **UP ARROW and DOWN ARROW KEYS:** depress and hold this push button to increase (UP ARROW) or decrease (DOWN ARROW) the setpoint temperature. If the push button is pressed momentarily the setpoint value is incremented or decremented by one degree. If the push button is held down the setpoint will increase or decrease continuously.
3. **SETPOINT LOCK OUT JUMPER:** this jumper controls whether the user is allowed to reduce the setpoint below 48°F or 9°C. If the jumper is in position 1 (farthest from the SPL label) the user IS NOT ALLOWED to reduce the setpoint below 48°F or 9°C. If the jumper is in position 2 (closest to the SPL label) the user is allowed to reduce the setpoint to 10°F or -11°C (figure 3.3D).

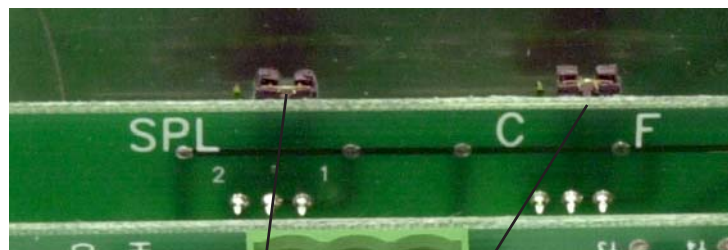

Figure 3.3D

Setpoint Lock Out Jumper Temperature Display Jumper

4. **TEMPERATURE DISPLAY JUMPER:** if this jumper is in the “F” position, the To Process and Setpoint temperatures are displayed in Fahrenheit. If the jumper is in the “C” position, the To Process and Setpoint temperatures are displayed in Celsius (figure 3.3D).
5. **Probe Calibration:** this pot (CALPOT 1) is used to calibrate the probe circuit .

D. STATUS LIGHTS

1. **COMPRESSOR:** illuminates when compressor is turned on.
2. **CAPACITY CONTROL:** illuminates when capacity control system is turned on.
3. **REFRIGERANT FAULT:** illuminates when there is a high pressure or low pressure alarm. Check troubleshooting section of this manual for more details.

High Pressure Fault. If the chiller control detects a high pressure condition it will immediately turn off the compressor and hot gas bypass.

Low Pressure Fault. After the compressor is turned on, the control has a 15 second buffer for the low pressure alarm. If a low pressure condition occurs within the first 15 seconds, the control waits the amount of time specified by the “LP TIME” potentiometer (figure 3.3E) before indicating an fault and turning off the compressor. If the condition is corrected before the time expires, no fault occurs. If a low pressure condition occurs 15 seconds after the compressor turns on, the instrument waits 20 seconds before indicating an alarm and turning off the compressor.

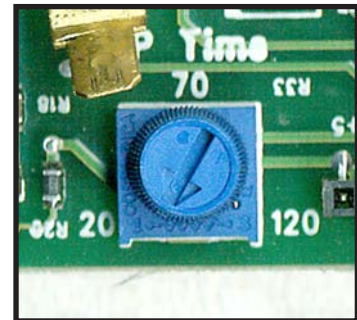

Low Pressure

Figure 3.3E

E. TEMPERATURE DISPLAY

1. A three digit display window indicates the appropriate temperature. The window also displays the numeric value for the setpoint temperature.
2. The To Process temperature is always displayed unless a button has been pressed. If there is a probe error, the display will show three dashes “---”.

F. PRESSURE GAUGES (optional item - may not apply to all units)

1. **PROCESS PRESSURE GAUGE:** indicates process pump pressure.
2. **REFRIGERANT HEAD PRESSURE GAUGE:** indicates refrigerant pressure on the discharge side of the compressor. The refrigerant head pressure is also the condensing pressure which is critical to equipment efficiency. Head pressure will vary with ambient temperatures between 190-290 psig.
3. **LOW PRESSURE GAUGE:** indicates refrigerant pressure on the suction side of the compressor. This pressure will fluctuate with the process temperature

3.4 SHUT DOWN/DISCONNECT SEQUENCE

A. PRECAUTIONS/WARNINGS

1. The operator must precisely follow all shut down procedures outlined in this manual. If the operator fails to follow precisely all procedures outlined in this manual, an unsafe condition can develop resulting in damage to the unit or personal injury.

B. UNIT SHUT DOWN

1. **To shut down the unit without disconnecting from the process:**
 - a. Move the ON / OFF switch to the off position.
 - b. Maintain electrical power to the unit at all times except for service purposes.
2. **To shut down the unit and disconnect from the process:**
 - a. Move the ON / OFF switch to the off position.
 - b. Disengage the electrical supply to the chiller at the disconnecting device.
 - c. Disconnect all process lines.
 - b. Disengage the electrical supply to the chiller at the disconnecting device.
 - c. Disconnect all process lines.

4.0 TROUBLESHOOTING

- 4.1** UNIT WILL NOT START
- 4.2** COMPRESSOR HUMS BUT WILL NOT START
- 4.3** SHUTS OFF ON HIGH PRESSURE CONTROL
- 4.4** SHUTS OFF ON LOW PRESSURE CONTROL
- 4.5** COMPRESSOR SHUTS OFF ON INTERNAL OVERLOAD
- 4.6** LOW OR NO PROCESS PRESSURE OR WATER FLOW
- 4.7** COOLING CAPACITY INADEQUATE
- 4.8** SENSOR
- 4.9** PUMPS
- 4.10** CRANKCASE HEATER
- 4.11** M1 CHILLER INSTRUMENT

4.1 UNIT WILL NOT START

- A. **Power off.** Check main disconnect.
- B. **Main line open.** Check fuses.
- C. **Loose terminals.** Tighten terminals with POWER OFF.
- D. **Control circuit open.** check control voltage fuses and transformer.

4.2 COMPRESSOR HUMS BUT WILL NOT START

- A. **Contactor.** Check contacts and contactor operation.
- B. **Low voltage.** Check voltage at main and at the unit. If voltage is OK at the main but low at the unit, increase wire size. If low at main, consult your local power company. Voltage must be +/- 10% nameplate rating.
- C. **No power on one phase of a three phase unit.** Check fuses in control panel and main disconnect. Also check unit wiring, main plant fuse and wiring. If the problem is with the main power supply coming into the plant, call the local power company.
- D. **Loose terminals.** Tighten terminals with POWER OFF.

4.3 SHUTS OFF ON HIGH PRESSURE CONTROL

Note. Refrigerant high pressure will vary with ambient temperature from minimum of 190 psi to as high as 280 psi. The high pressure switch manually reset when discharge pressure falls to a safe level. The switch is located inside the electrical panel.

- A. **Air-cooled units:**
 - 1. **Insufficient condenser air flow.** Check condenser filter for dirt, fins may be plugged with dirt or foreign material. Also, check for proper fan rotation.
 - 2. **Fan motor not operating.** Have electrician check fuses and wiring, motor starter and overloads, and motor. Repair or replace motor if defective.
- B. **Excess refrigerant.** have refrigeration serviceman purge system while operating until bubbles first appear in sight glass. The have the unit recharged until sight glass clears.
- C. **Air in system.** Have refrigeration serviceman purge the system.

- D. **Improperly set high pressure control.** Have refrigeration serviceman reset or replace the control if defective.

4.4 SHUTS OFF ON LOW PRESSURE CONTROL

Note: The low pressure switch will automatically resets when the pressure rises above the cut-in pressure. If this does not occur contact the Advantage service department for instructions.

The low pressure switch is set to cut-out at 58 psi and cut-in at 63 psi. If a low pressure condition exists for more than five seconds the compressor will stop and a “L-P” fault will appear in the display window.

After the refrigerant pressure rises above the cut-in pressure, a three minute time delay will occur before the compressor restarts. This will protect the evaporator and compressor from damage should a problem occur in the refrigeration system or if the chiller is operated under circumstances which could cause damage to the refrigeration system.

A. **Air-cooled units:**

Head pressure too low. Low pressure flooding control not operating properly. Have unit diagnosed by a refrigerant serviceman.

- B. **Low refrigerant charge.** Check for adequate refrigerant charge (bubbles or misty sight glass indicates low charge). If charge is low, have system checked for leaks and recharged by a refrigeration serviceman.

- C. **Improperly set low pressure switch.** Have a refrigeration serviceman reset control or replace if defective.

D. **Restriction in the liquid line.**

1. **Clogged filter drier.** Check for pressure or temperature drop and have drier core replaced by a refrigeration serviceman.
2. **Liquid line valve or suction valve on compressor is partially closed.** Open fully.
3. **Liquid line solenoid not opening fully or leaking during off cycle.** have repaired or replaced if defective by a refrigeration serviceman.
4. **Expansion valve plugged or inoperative.** Check thermal bulb and capillary tube for damage. Have repaired or replaced if defective by a refrigeration serviceman.

4.5 COMPRESSOR SHUTS OFF ON INTERNAL OVERLOAD

- A. **Control does not reset.** Have compressor windings and internal solid state safety control checked by a refrigeration serviceman. Have it repaired or replace if defective.

4.6 LOW OR NO PROCESS PRESSURE OR WATER FLOW

- A. **Valves.** Check if water valves are open.
- B. **Pump.** Check pump for correct rotation. Check pump suction for restriction. Replace motor if defective.
- C. **Filters.** Check filter in the chilled water circuit and clean if necessary.
- D. **Fuses and wiring.** Have electrician check the fuses and wiring.

4.7 COOLING CAPACITY INADEQUATE

- A. **Low refrigerant charge.** Check for adequate refrigerant charge (bubbles or misty sight glass indicates low charge). If charge is low, have system checked for leaks and recharged by a refrigeration serviceman.
- B. **Hot-gas bypass valve stuck open.** Have repaired or replace if defective by a refrigeration serviceman.
- C. **Expansion valve plugged or inoperative.** Check thermal bulb and capillary tube for damage. Have repaired or replaced if defective by a refrigeration serviceman.
- D. **Plugged filter.** Check filter in chilled water circuit and clean.
- E. **Air in system.** Purge air.

4.8 SENSOR

The sensor is a solid state temperature transducer which converts temperature input to proportional current output. To quickly test for a defective probe, switch connections between the defective probe and a probe known to be working properly. A defective sensor will display a "---" in the display window on the instrument control.

4.9 PUMPS

- A. The centrifugal pump is designed to operate at a specific flow and pressure at the maximum run load amp draw of the motor. Too

much flow can overload the motor and cause the overload circuit to open and stop the pump.

- B.** If the overload trips, check for electrical shorts, loose wires, or blown fuses. If these check OK, reset the overload circuit and restart the chiller.
- C.** Check the amp draw and if overloaded, partially close the from process line valve until the amp draw drops to the proper level.

4.10 **CRANKCASE HEATER** (may not apply to D1 Series units)

- A.** If the crankcase heater is not drawing current during the compressor off cycle, check for a defective crankcase heater, defective fuses or defective interlock on the compressor starter.
- B.** Scroll compressors do not have crankcase heaters.

4.11 **M1 CHILLER INSTRUMENT**

- A.** The display is used for all normal set ups, diagnostics, temperature readout, and operational information. **Note:** the display is not field repairable. It can be easily removed and replaced if required.
- B.** The M1 chiller instrument is mounted in a remote control enclosure with remote cable. Do not disassemble the instrument. The instrument is not field repairable but it can be easily removed and replaced if required. Contact the factory for replacement procedures, costs and policies.

THIS PAGE INTENTIONALLY BLANK

5.0 MAINTENANCE

- 5.1** WARRANTY SERVICE PROCEDURE
- 5.2** PERIODIC PREVENTATIVE MAINTENANCE
- 5.3** SPECIAL MAINTENANCE
- 5.4** PUMP SEAL SERVICE
- 5.5** CHECKING THE REFRIGERANT CHARGE
- 5.6** PROPER CLEANING PROCEDURE FOR BRAZED PLATE EVAPORATOR



5.1 WARRANTY SERVICE PROCEDURE

- A. In the event of a problem with a chiller that can not be resolved by normal troubleshooting procedures, the customer is invited to consult the Advantage service department for assistance. The correct model number and serial number of the chiller must be available. The service department will attempt to isolate the problem and advise repair procedures. Often times, with the customer's input and with the machine diagnostics, problems can be determined with "over-the-phone" consultation.
- B. If the problem is beyond the scope of "over-the-phone" consultation, and if the warranty status of the machine is valid, Advantage will contact the nearest authorized service contractor and provide authorization to conduct an "on-site" inspection of the unit in order to determine the course of repair. If the chiller is not covered by the warranty, Advantage will advise on the repair and recommend available service contractors.
- C. Advantage manufactures a complete line of heat transfer equipment. It is of the utmost importance that Advantage have the correct model number and serial number of the machine in question. This will allow Advantage to obtain the correct manufacturing records which will help the service department to properly troubleshoot the problem and obtain the proper replacement parts when they are required. This information is stamped on the metal data tag that is attached to the electrical enclosure of each machine.
- D. The Advantage service department must be notified prior to any repair or service of a warranty nature. Warranty claims will not be honored without prior authorization.

5.2 PERIODIC PREVENTATIVE MAINTENANCE

- A. Lubricate all motors. Note that some motors are supplied with sealed bearings.
- B. Tighten all wire terminals.
- C. Clean and check motor starter and contactor contacts.
- D. Check safety switch settings.
- E. Clean condenser fins of dust and dirt (air cooled models only).
- F. Back flush evaporator.
- G. Check glycol/water solution ratio for operating temperature.
- H. Check system for leaks.

- I. Refrigerant sight glass: check for bubbles when compressor is operating at 100%. Check the moisture indicator for a color other than green.
- J. Clean unit.

5.3 SPECIAL MAINTENANCE

- A. Any service of the refrigeration system must be accomplished by a certified refrigeration technician.
 - 1. Vacuum check compressor.
 - 2. Addition of compressor oil.
 - 3. Addition of refrigerant.
 - 4. Repair of a refrigerant leak.
 - 5. Adjustment of super heat.
 - 6. Changing of filter-drier or drier core.
 - 7. Repair of a refrigeration solenoid.
 - 8. Valve plate replacement on compressor.

5.4 PUMP SEAL SERVICE

A. The coolant pump seal is a carbon/niresist shaft seal assembly including a stationary member, rotating member and tension spring (figure 5.5A).

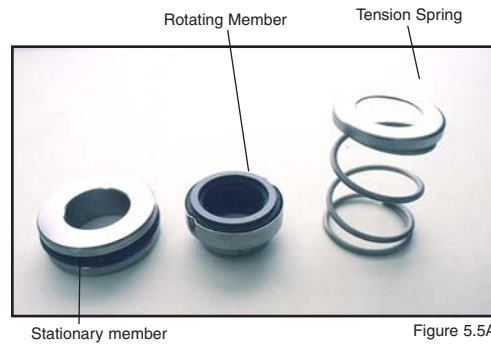

B. The operator can determine the pump seal is leaking when fluid is identified leaking from the pump case adapter. Generally, a pump seal will leak due to inadequate unit pressure, excessive flow and poor fluid quality.

C. The operator should follow this procedure to replace the pump seal:

1. Disengage process operations according to the procedure outlined in section 3.4. The operator must be certain process fluid temperature is under 100°F and pressure is relieved (COOLANT pressure gauge reads “0”) and water make-up flow is shut off and all pressure relieved.
2. Disengage main power supply. The operator must verify the POWER light on the display is “off”.
3. Access the pump motor by opening or removing any cover panels as necessary (figure 5.5B).
4. Drain machine. The machine can be drained by using the drain valve located on the pump case. Drain fluid into a suitable container for reuse or disposal according to manufacturer’s instructions (if a glycol solution is used).
5. Locate and remove the three motor wire leads from the motor wiring terminals. The operator should “map”



Figure 5.5B

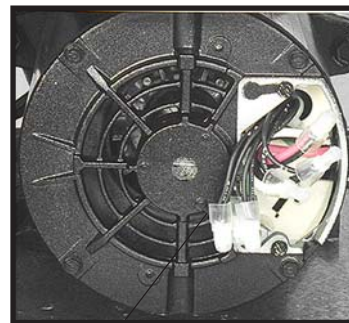
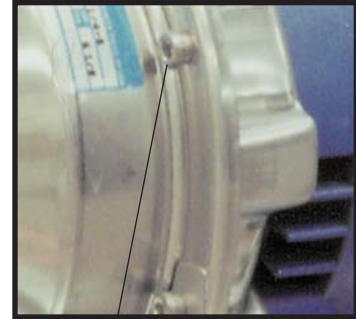

Figure 5.5C

the wire terminal locations to ensure correct rewiring. The power cord should be removed from the motor housing (figure 5.5C).

6. Locate and remove the pump casing bolts. These bolts secure the motor and motor adapter to the pump casing (figure 5.5D).



Typical pump casing bolt Figure 5.5D

7. Separate the motor and motor adapter from the pump casing to expose the pump impeller (figure 5.5E). Remove the motor and motor adapter from the unit and place on a workbench to continue the procedure.

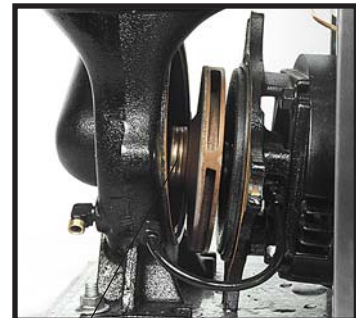

Impeller Figure 5.5E

8. Locate and remove the dust cap from motor end to expose slotted motor shaft. The motor shaft is free to rotate, but must be secured to remove the impeller. To secure the motor shaft, insert a flat bladed screw driver in slot to hold the shaft stationary (Figure 5.5F).

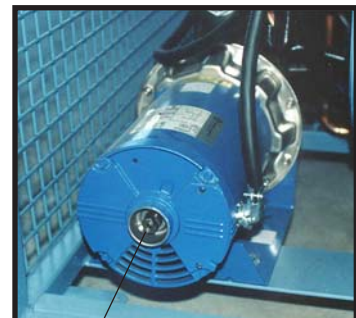

Motor shaft Figure 5.5F

9. Locate and remove impeller locking screw (Figure 5.5G). Using a socket and ratchet, the impeller retaining screw can be removed. Once the retaining screw is removed, the impeller can be “unthreaded” from the motor shaft to expose the pump seal assembly.

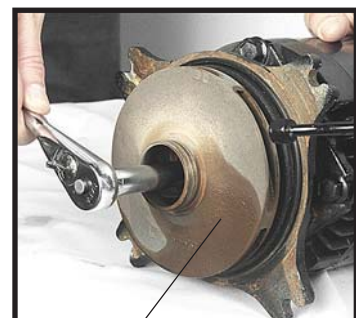

Typical impeller Figure 5.5G

10. Remove all seal parts (Figure 5.5H). Note seal component arrangement to facilitate reassembly.

11. Clean motor shaft and lubricate with a mild soap solution.
 12. Install new stationary seal member in pump casing cavity (figure 5.5I). The operator must be certain the stationary seal member is fully squared and seated in cavity.
 13. Slide the rotating member onto lubricated pump shaft (figure 5.5J). The operator must be certain not to damage or tear rubber bellows assembly.
 14. Place the spring onto the rotating member.
 15. Align the impeller, spring and rotating member before reinstalling the impeller (figure 5.5K). The operator must be certain the spring and rotating member are aligned before the impeller is fully tighten and the impeller retaining screw is reinstalled.
 16. Clean pump casing, cavities, impeller and O-ring before reassembly.
 17. Mate the motor and motor adapter to the pump casing. Reinstall the pump casing bolts.
 18. Reconnect the motor power cord and leads.
 19. Restore all cover panels as were removed.
- E. When the pump seal replacement procedure is complete, the operator may restart the unit according to the section 3.



Seal components

Figure 5.5H



Stationary member

Figure 5.5I



Stationary member

Figure 5.5J



Seal members

Figure 5.5K

5.5 CHECKING THE REFRIGERANT CHARGE

- A. All standard chillers are manufactured with thermostatic expansion valves as the metering device to the evaporator.
- B. All chillers have a refrigerant sight glass (figure 5.6A) with a moisture indicator. To check the refrigerant charge under normal operating conditions:

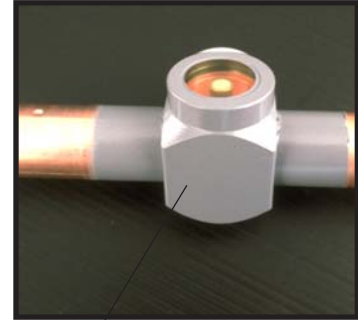

Sight Glass

Figure 5.6A

1. Remove the plastic cap covering the sight glass.
2. Start the chiller and allow system pressures and temperatures to stabilize.
3. With the unit operating at 100% capacity (not in the “capacity control” mode) the sight glass should appear clear with no foam or bubbles evident. If foam or bubbles are evident, the chiller has suffered from a loss of refrigerant and should be checked by a qualified refrigeration technician.
4. The “dot” in the middle of the sight glass is the moisture indicator. It should appear green at all times. A white or yellow color indicates moisture has invaded the refrigeration system, which is detrimental to the life of the compressor. The filter-drier should be replaced by a qualified refrigeration technician.

5.6 PROPER CLEANING PROCEDURE FOR BRAZED PLATE EVAPORATORS

- A.** The brazed plate evaporator is made of stamped stainless steel plates, furnace brazed together with copper based joints. The complex geometry of the flow passages promotes turbulent flow which gives high efficiency and reduces fouling by mineral deposits. Large solids such as plastic pellets or chunks of mineral deposits will collect at the water inlet port at the evaporator and restrict flow through some of the passages. If this possibility exists, the factory recommends filters or strainers be added to the “from process” line. If the evaporator becomes fouled there are a couple of methods for cleaning.

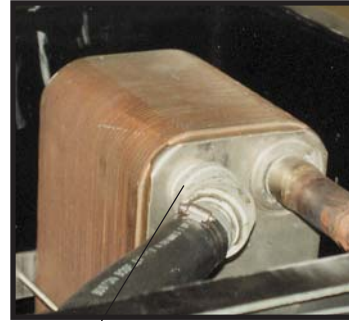

Evaporator

Figure 5.6A

- B.** To begin, remove the piping to the “water in” port at the evaporator. Remove any solids that have collected at this point. Then back flush the evaporator to remove any solids that may be trapped between the plates (see back flush procedure below). If there are mineral deposits adhered to the plates, the evaporator must be back flushed with a mild acid solution (5% phosphoric or 5% oxalic acid is recommended.) After cleaning rinse with clear water before returning to service. Continue with step C on the next page.

C. Back flushing procedure:

1. Turn off all power to the machine. For chillers with a reservoir tank, drain the tank to below the evaporator outlet. For chillers without a reservoir tank, drain total unit.
2. Connect a water supply hose to the evaporator water outlet. If acid cleaning, connect the discharge hose from the acid pump to the evaporator outlet port.
3. Connect a hose to the evaporator water supply port and to an appropriate containment vessel. If acid cleaning, connect the evaporator water inlet port to an acid solution reservoir tank. Dispose of all back flush fluid according to local codes.
4. The cleaning fluid source should have at least 20 psi available. If acid cleaning, follow the instructions supplied with the acid solution carefully.
5. When the procedure is complete, reinstall all water lines to original factory orientation. Restart the unit and check for proper operation.

6. **Note:** this procedure is not normal maintenance. Maintaining proper water quality and filtration will minimize the need to back flush the evaporator.

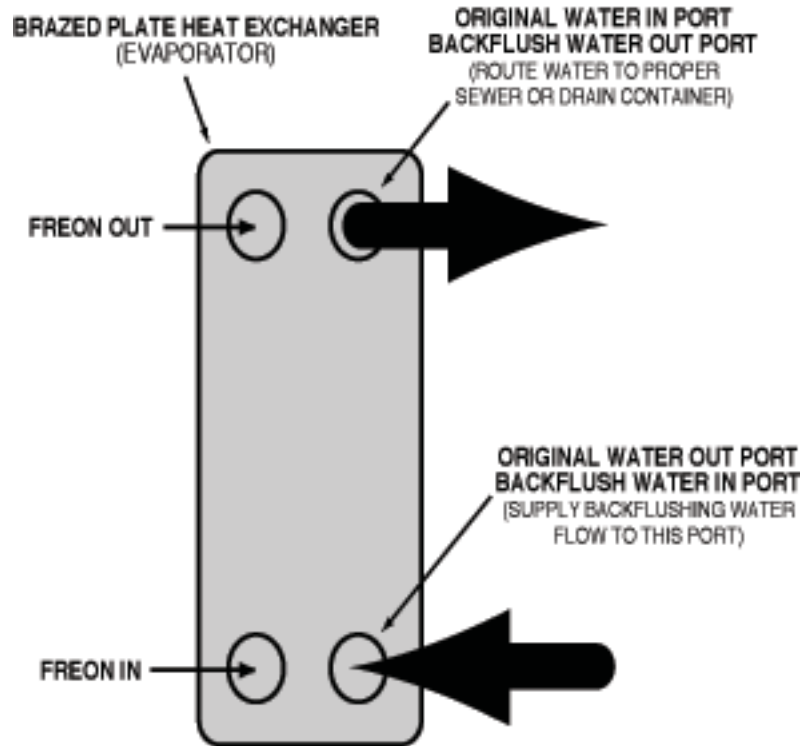

THIS PAGE INTENTIONALLY BLANK

6.0 COMPONENTS

- 6.1** WATER SYSTEM
- 6.2** REFRIGERATION SYSTEM



6.1 WATER SYSTEM

- A. MOTOR/PUMP ASSEMBLY:** the motor/pump assembly circulates chilled fluid to the process loop. The pump assembly is built of total stainless steel to maintain water quality (figure 6.1A).



Typical pump

Figure 6.1A

6.2 REFRIGERATION SYSTEM

- A. COMPRESSOR:** compressors take low pressure/low temperature refrigerant gas and compress the gas into high pressure/high temperature gas (figure 6.2A).



Typical compressor

Figure 6.2A

- B. AIR COOLED CONDENSER:** the air cooled condenser removes BTU's from the compressed refrigerant gas. The action causes the gas to "condense" into a liquid state still under high pressure. Air flow across the condenser is achieved via a motor driven fan assembly or centrifugal blower (figure 6.2B).

- C. FILTER-DRIER:** the filter-drier removes contaminants and moisture from the liquid refrigerant (figure 6.2B).



Typical filter-drier

Figure 6.2B

- D. LIQUID LINE SOLENOID VALVE:** controlled by the instrument, this valve closes when the compressor cycles off to prevent refrigerant liquid from migrating to the evaporator. The valve opens when the compressor cycles on.

- E. REFRIGERANT SIGHT GLASS:** the refrigerant sight glass indicates refrigerant charge and moisture content. Refrigerant charge is determined by a clear liquid flow. Bubbles indicate low refrigerant. Moisture content is indicated by the color of the element. Element color



Refrigerant sight glass

Figure 6.2C

is normally green. If the color of the element is chartreuse or yellow, the system has been contaminated with moisture. In such case, the filter-drier must be replaced. The replacement of the filter-drier must be completed by a qualified refrigerant service technician (figure 6.2C).

F. EXPANSION VALVE: the expansion valve throttles flow of refrigerant liquid into the evaporator and creates a pressure drop in the refrigerant system that allows the liquid refrigerant to “boil off” inside the evaporator (figure 6.2D).



Expansion Valve

Figure 6.2D

G. EVAPORATOR: the evaporator is a brazed plate heat exchanger where the refrigerant liquid is allowed to evaporate (boil off) to absorb heat (BTU) from the process fluid. As the heat is absorbed, the process fluid is chilled.

H. HOT GAS BY-PASS SOLENOID: the hot gas by-pass solenoid prevents short cycling of the compressor by reducing the capacity by 50% when the process fluid temperature nears the setpoint.

I. HIGH/LOW PRESSURE STATS: the high/low pressure stats protect the refrigeration system from unsafe operating levels. The **high pressure switch** is factory set to open at 325 psi and protects the refrigeration components and personnel from potential damage of injury from excessive high pressure. The high pressure safety must not be altered in the field for any reason. The **low pressure switch** is factory set to open at 58 psi and to close at 63 psi. The low pressure switch protects the chillers from possible damage due to low operating pressure. The low pressure switch is field adjustable for setpoints below 48°F.

NEVER LOWER THE CUT OUT SETTING WITHOUT ADDING GLYCOL TO THE CIRCULATING SYSTEM. EVAPORATOR DAMAGE WILL RESULT AND WILL NOT BE COVERED BY THE WARRANTY.

J. Liquid receiver: located after the condenser, this component receives and stores liquid refrigerant leaving the condenser.

K. Service valves: have been provided throughout the system. Only a qualified refrigeration service technician shall operate these valves.

THIS PAGE INTENTIONALLY BLANK

7.0 APPENDIX

- 7.1** OPERATIONS BELOW 48°F FLUID OR 38°F AMBIENT
- 7.2** INHIBITED PROPYLENE GLYCOL
- 7.3** WATER QUALITY CONTROL
- 7.4** SENSOR CURRENT VS TEMPERATURE CHART
- 7.5** REFRIGERANT PRESSURE-TEMPERATURE CHART
- 7.6** HILLER CAPACITY AND DERATE CHART
- 7.7** AIR-COOLED MECHANICAL SCHEMATIC



8.1 OPERATIONS BELOW 48°F FLUID OR 38°F AMBIENT

- A.** The chiller is never to be operated below 48°F leaving water temperature without several precautionary measures. All controls are factory adjusted for 48°F and above operations.
- B.** Before readjusting the protective devices, a satisfactory antifreeze solution must be substituted for the recirculating chilled water. This mixture will consist of inhibited propylene glycol and water. Do not substitute an inhibited propylene glycol and water solution with common automotive type antifreeze. This chart outlines the glycol percentages at various water temperatures.
- C.** Fluid must be tested with a hydrometer to verify proper glycol percentages for freeze protection. The ratio shall be according to the chart below. Too much glycol can cause capacity and control problems.
- D. DO NOT USE AUTOMOTIVE TYPE ANTI-FREEZE.**
- E.** Once the antifreeze provision is satisfied, the freezestat safety switch may be readjusted. Adjust the freezestat according to this chart.
- F.** Adjust the low pressure safety switch according to the specifications in the chart below.

Refrigerant Low Pressure Switch Cut-Out & Cut-In Settings

Ambient Temperature	Operating Temperature	Glycol	Freeze Point	Cut Out Temp	Cut In Temp	R22		R134A		R410A	
						Cut-Out	Cut-In	Cut-Out	Cut-In	Cut-Out	Cut-In
39°F +	48° - 70°F	0%	32°F	32°F	36°F - 39°F	58#	63#	28#	33#	102#	111#
15° to 38°F	25° - 47°F	30%	10°F	10°F	15°F - 18°F	33#	38#	12#	17#	63#	72#
0° to 14°F	10° - 24°F	40%	-5°F	-5°F	0°F - 7°F	20#	25#	4#	9#	43#	52#
-10° to 0°F	n/a	45%									
-20° to -10°F	n/a	50%									

Ambient Temperature	Operating Temperature	Glycol	Freeze Point	Cut Out Temp	Cut In Temp	R404A		R407C	
						Cut-Out	Cut-In	Cut-Out	Cut-In
39°F +	48° - 70°F	0%	32°F	32°F	36°F - 39°F	72#	79#	52#	58#
15° to 38°F	25° - 47°F	30%	10°F	10°F	15°F - 18°F	44#	49#	28#	34#
0° to 14°F	10° - 24°F	40%	-5°F	-5°F	0°F - 7°F	29#	34#	16#	22#
-10° to 0°F	n/a	45%							
-20° to -10°F	n/a	50%							

High Pressure Cut Out (maximum) (with liquid receiver)

Refrigerant	Air-Cooled
R22	360#
R134A	260#
R407C	360#
R410A	550#
R404A	360#



- G. Once all safety provisions are made, the temperature control thermostat may now be lowered to the desired operating temperature.
- H. **WARNING:** do not use any type or brand of automotive antifreeze. Automotive antifreeze contains corrosion inhibitors - silicates - designed for compatibility with the materials in automotive engines. Unfortunately, silicates can gel and cause deposits to foul and insulate heat exchanger surfaces. In your chilling system that can mean higher energy costs, high pumping costs, and possibly even shut downs for system cleaning. We recommend the use of DowFrost or Monsanto DFS-1.

7.2 INHIBITED PROPYLENE GLYCOL

- A. To operate liquid chillers below 48°F LPT, it is necessary to add **inhibited propylene glycol** to the circulating system to lower the freeze point and prevent damage to the cooling system. Inhibited propylene glycol contains corrosion inhibitors which are compatible with most industrial heat transfer surfaces. Inhibited propylene glycol is manufactured by:
 - Dow Chemical - “DowFrost” (1-800-258-2436)
 - Monsanto “Therminol FS” (1-800-459-2665)
 - Advantage Engineering “Thermofluid” (1-317-887-0729)
- B. Automotive anti-freeze must never be used in industrial heat transfer applications. Automotive anti-freeze contains silicate type corrosion inhibitors designed to be compatible with automotive components. In an industrial application, the silicates will form a gel on the heat transfer surface which will result in substantial reduction in cooling capacity and is virtually impossible to remove.

7.3 WATER QUALITY CONTROL

- A. Lack of, as well as, improper water treatment can damage the chilling unit. The services of a competent water treatment specialist should be obtained and their recommendations followed. It is the equipment owner’s responsibility to prevent damage from foreign material or inadequate water treatment.
- B. The two main things to consider for water treatment in chillers are corrosion and organism growth. Proper chemical treatment can control PH levels and algae growth. An alternative to chemical treatment is the addition of 20% inhibited propylene glycol to the water. This will help prevent organism growth and coat the heat transfer surfaces with corrosion inhibitor.

7.4 SENSOR CURRENT VS TEMPERATURE

-20°F = 243.86	A
-10°F = 249.43	A
0°F = 255.00	A
10°F = 260.57	A
20°F = 266.14	A
30°F = 271.71	A
40°F = 277.27	A
50°F = 282.84	A
60°F = 288.41	A
70°F = 293.98	A
80°F = 299.55	A
90°F = 305.12	A
100°F = 310.69	A
110°F = 316.26	A
120°F = 321.82	A
130°F = 327.39	A
140°F = 332.96	A
150°F = 338.53	A
160°F = 344.10	A
170°F = 349.67	A
180°F = 355.24	A
190°F = 360.80	A
200°F = 366.37	A
210°F = 371.94	A
220°F = 377.51	A
230°F = 383.08	A
240°F = 388.65	A
250°F = 394.22	A

Formula:

- $1 \mu A = (556.8627 \times 10 \times \text{°F}) = (255 \times 10)$
- $\text{°F} = (1 \mu A - 255 \times 10) + (556.8627 \times 10)$

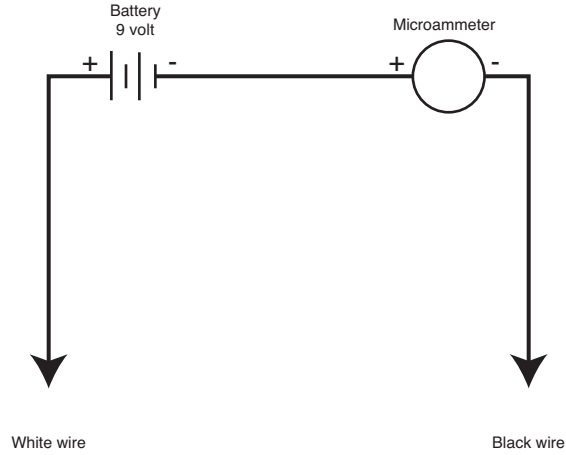

7.5 PRESSURE-TEMPERATURE CHART FOR R-22 REFRIGERANT

Refrigerant Pressure Temperature Chart

Temperature		Refrigerant				
°F	°C	R-22	R-410a	R-407c	R-134a	R-404a
-60	-51.1	<i>11.9</i>	<i>0.9</i>	<i>16.0</i>	<i>21.6</i>	-
-55	-48.3	<i>9.2</i>	1.8	<i>13.7</i>	<i>20.2</i>	-
-50	-45.6	<i>6.1</i>	4.3	<i>11.1</i>	<i>18.6</i>	-
-45	-42.8	<i>2.7</i>	7.0	<i>8.1</i>	<i>16.7</i>	-
-40	-40.0	0.6	10.1	<i>4.8</i>	<i>14.7</i>	4.9
-35	-37.2	2.6	13.5	<i>1.1</i>	<i>12.3</i>	7.5
-30	-34.4	4.9	17.2	1.5	<i>9.7</i>	10.3
-25	-31.7	7.5	21.4	3.7	<i>6.8</i>	13.5
-20	-28.9	10.2	25.9	6.2	<i>3.6</i>	16.8
-18	-27.8	11.4	27.8	7.2	<i>2.2</i>	18.3
-16	-26.7	12.6	29.7	8.4	<i>0.7</i>	19.8
-14	-25.6	13.9	31.8	9.5	0.4	21.3
-12	-24.4	15.2	33.9	10.7	1.2	22.9
-10	-23.3	16.5	36.1	11.9	2.0	24.6
-8	-22.2	17.9	38.4	13.2	2.8	26.3
-6	-21.1	19.4	40.7	14.6	3.7	28.0
-4	-20.0	20.9	43.1	15.9	4.6	29.8
-2	-18.9	22.4	45.6	17.4	5.5	31.7
0	-17.8	24.0	48.2	18.9	6.5	33.7
1	-17.2	24.8	49.5	19.6	7.0	34.7
2	-16.7	25.7	50.9	20.4	7.5	35.7
3	-16.1	26.5	52.2	21.2	8.0	36.7
4	-15.6	27.4	53.6	22.0	8.6	37.7
5	-15.0	28.3	55.0	22.8	9.1	38.8
6	-14.4	29.1	56.4	23.7	9.7	39.8
7	-13.9	30.0	57.9	24.5	10.2	40.9
8	-13.3	31.0	59.3	25.4	10.8	42.0
9	-12.8	31.9	60.8	26.2	11.4	43.1
10	-12.2	32.8	62.3	27.1	12.0	44.3
11	-11.7	33.8	63.9	28.0	12.6	45.4
12	-11.1	34.8	65.4	29.0	13.2	46.6
13	-10.6	35.8	67.0	29.9	13.8	47.8
14	-10.0	36.8	68.6	30.9	14.4	49.0
15	-9.4	37.8	70.2	31.8	15.1	50.2
16	-8.9	38.8	71.9	32.8	15.7	51.5
17	-8.3	39.9	73.5	33.8	16.4	52.7
18	-7.8	40.9	75.2	34.8	17.1	54.0
19	-7.2	42.0	77.0	35.9	17.7	55.3
20	-6.7	43.1	78.7	36.9	18.4	56.6
21	-6.1	44.2	80.5	38.0	19.2	57.9
22	-5.6	45.3	82.3	39.1	19.9	59.3
23	-5.0	46.5	84.1	40.2	20.6	60.6
24	-4.4	47.6	85.9	41.3	21.4	62.0
25	-3.9	48.8	87.8	42.4	22.1	63.4
26	-3.3	50.0	89.7	43.6	22.9	64.8

Temperature		Refrigerant				
°F	°C	R-22	R-410a	R-407c	R-134a	R-404a
27	-2.8	51.2	91.6	44.7	23.7	66.2
28	-2.2	52.4	93.5	45.9	24.5	67.7
29	-1.7	53.7	95.5	47.1	25.3	69.2
30	-1.1	54.9	97.5	48.4	26.1	70.7
31	-0.6	56.2	99.5	49.6	26.9	72.1
32	0.0	57.5	101.6	50.9	27.8	73.8
33	0.6	58.8	103.6	52.1	28.6	75.3
34	1.1	60.2	105.7	53.4	29.5	76.9
35	1.7	61.5	107.9	54.8	30.4	78.5
36	2.2	62.9	110.0	56.1	31.3	80.2
37	2.8	64.3	112.2	57.5	32.2	81.7
38	3.3	65.7	114.4	58.9	33.1	83.5
39	3.9	67.1	116.7	60.3	34.1	85.2
40	4.4	68.6	118.9	61.7	35.0	86.9
41	5.0	70.0	121.2	63.1	36.0	88.6
42	5.6	71.5	123.6	64.6	37.0	90.4
43	6.1	73.0	125.9	66.1	38.0	92.2
44	6.7	74.5	128.3	67.6	39.0	94.0
45	7.2	76.1	130.7	69.1	40.0	95.8
46	7.8	77.6	133.2	70.6	41.1	97.6
47	8.3	79.2	135.6	72.2	42.2	99.5
48	8.9	80.8	138.2	73.8	43.2	101.4
49	9.4	82.4	140.7	75.4	44.3	103.3
50	10.0	84.1	143.3	77.1	45.4	105.3
55	12.8	92.6	156.6	106.0	51.2	115.3
60	15.6	101.6	170.7	116.2	57.4	126.0
65	18.3	111.3	185.7	127.0	64.0	137.4
70	21.1	121.5	201.5	138.5	71.1	149.3
75	23.9	132.2	218.2	150.6	78.6	161.9
80	26.7	143.7	235.9	163.5	86.7	175.4
85	29.4	155.7	254.6	177.0	95.2	189.6
90	32.2	168.4	274.3	191.3	104.3	204.5
95	35.0	181.9	295.0	206.4	113.9	220.2
100	37.8	196.0	316.9	222.3	124.1	236.8
105	40.6	210.8	339.9	239.0	134.9	254.2
110	43.3	226.4	364.1	256.5	146.3	272.5
115	46.1	242.8	389.6	274.9	158.4	291.9
120	48.9	260.0	416.4	294.2	171.1	312.1
125	51.7	278.1	444.5	314.5	184.5	333.4
130	54.4	297.0	474.0	335.7	198.7	355.6
135	57.2	316.7	505.0	357.8	213.5	379.1
140	60.0	337.4	537.6	380.9	229.2	403.7
145	62.8	359.1	571.7	405.1	245.6	429.6
150	65.6	381.7	607.6	430.3	262.8	456.8
155	68.3	405.4	645.2	456.6	281.0	484.8

Italics indicates vacuum (inches of mercury)

Standard font indicates pressure (pounds per inch gauge)



7.6 CHILLER CAPACITY AND DERATE CHART

Standard chiller rating is at 50°F. For all other temperature settings, output tonnage is altered as follows:

OUTPUT TEMPERATURE °F	FULL AVAILABLE % CAPACITY
60	105%
50	100%
45	90%
40	80%
35	70%
30	60%
25	50%
20	40%
15	30% *
10	22% *
5	15% *
0	9% *
-5	5% *

NOTES:

If operation of the chiller at less than 48°F is required, an inhibited propylene glycol solution is required.

Consult factory for chiller operation below 20°F.

Ambient conditions affect air cooled chiller operation and capacity. Standard rating is at 95°F entering air temperature. For ambient air conditions greater than 95°F, chiller derating will occur. For ambient of 95-105°F, select the next larger capacity chiller. For ambient over 105°F, consult factory.

* These ranges require special options.



7.7 AIR-COOLED MECHANICAL SCHEMATIC

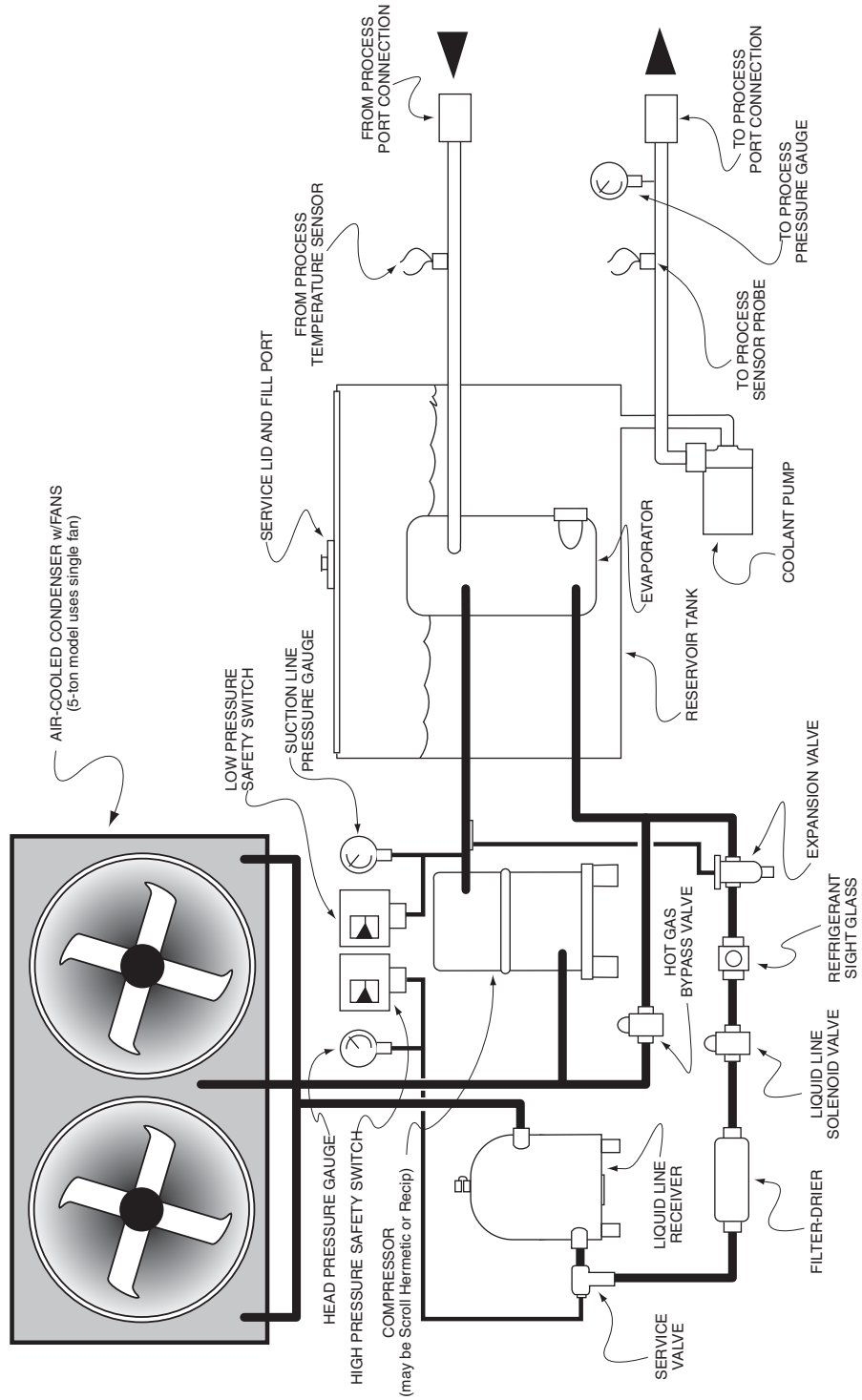

THIS PAGE INTENTIONALLY BLANK

END

© 2010 ADVANTAGE ENGINEERING, INC.

RE 2 7/10

