

Web: www.AdvantageEngineering.com

Phone: 317-887-0729

• Temperature Control Units

Water & Oil
30° - 500°F

• Portable Chillers

Air & Water-Cooled
20° - 70°F

• Central Chillers

Air & Water-Cooled
Packages & Modules
20° - 70°F

• Pump Tank Stations

Chilled or Tower Water
200 - 3200 gallons

• Cooling Tower Cells

45 - 540 tons

• Filters

• Heat Exchangers

• Heat Recovery Units

WARRANTIES

1 Year covering the pumping system.

10 Years tank failure of the Tough Tank® reservoir.

TOUGH TANK® & PTS-CPTS SERIES

For Use With **Tower** or **Chilled** Water systems



TTK-1600-3P shown in Conventional configuration with these features:

- Standby pump and manifold
- Central control console
- Pressure and temperature alarms
- Electric water make-up system
- CheckMate™ system control instrument

Tough Tank® Series Pump Tank Stations

• 450, 850, 1,600 & 3,200 Gallon Capacities

• Engineered Pump Selections To Meet Your Flow & Pressure Requirements

• 10 Year Tank Failure Warranty

checkmate™

**CONTROL
INSTRUMENT FOR
MAXIMUM CONTROL
AND MONITORING**



PTS-CPTS Series Pump Tank Stations

• 275 - 3,000 Gallon Capacities

• Engineered Pump Selections To Meet Your Flow & Pressure Requirements



PTS-2000 shown with optional features:

- Standby pump and manifold
- Central control console
- Pressure and temperature alarm system
- Electric water make-up system
- CheckMate™ system control instrument

APPLICATIONS

Advantage Pump Tanks can be used to circulate tower or chilled water to a variety of process applications:



Molds & Dies



Nozzles, Barrels & Tools



Heat Exchangers

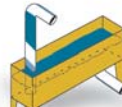

Troughs & Tanks



Rolls



Radiators and Air Coils

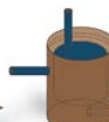

Jacketed Vessels and Mixers

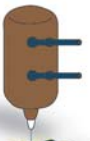

Lasers



PUMP TANK SYSTEMS

Advantage pump tank systems are used to support cooling equipment including evaporative cooling towers, central chillers and fluid coolers. Pump tank systems consist of a vented reservoir along with fluid pumps and controls specifically selected to meet the needs of your process and/or entire facility. The standard unit is designed to be installed indoors or protected from the elements.

Use of a pump tank assembly improves plant cooling effectiveness by providing a stable reserve of cooling fluid to moderate the affects of rapid load changes and to provide a place for air to separate from the system and for debris to settle out of the recirculating water flow. A pump tank also provides a convenient location to monitor water quality and introduce chemical treatment.

Experienced application specialists review each application to provide the proper fluid flow, pressure and temperature for each unique system. Every central water system includes water distribution piping drawings suitable for contractor bidding and installation work.

1-Pump Systems... circulate the cooling fluid to process then directly back through the chiller or cooling tower. Flow rate variation must be kept to a minimum with 1-pump systems. This system can be equipped with an optional standby pump. Full suction and discharge manifolds are included with the purchase of a standby pump.

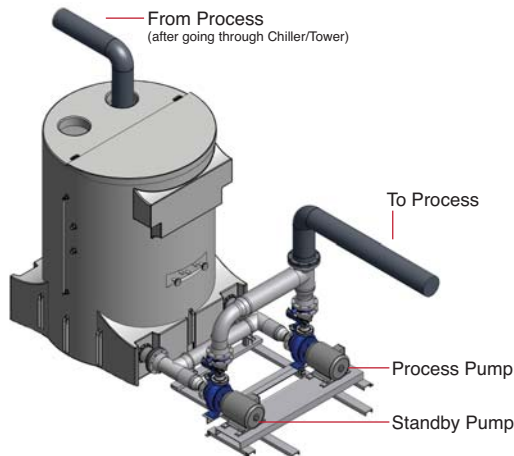

2-Pump Systems... process flow rates often fluctuate and can be higher or lower than the cooling tower or chiller requires for optimum performance. 2-Pump systems are preferred for most applications because constant and optimum flow and pressure is maintained through the cooling tower or chiller regardless of the process flow. 2-Pump systems can be equipped with an optional standby pump that can support either the process or recirculating pumps. Discrete standby pumps are also available as an option. Full suction and discharge manifolds are included with the purchase of a standby pump.

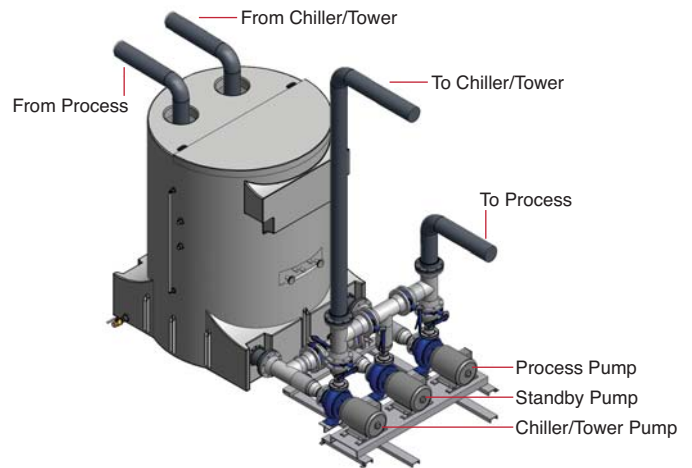

RESERVOIRS



Polyethylene Reservoir

As a guideline, reservoir volume is selected to provide at least one (1) minute of residence time in the tank. Reservoirs are offered in three materials: polyethylene, mild steel and stainless steel. All include a drain port with valve, mechanical water make-up valve and overflow port. On chilled water systems, 3/8" dense foam insulation is applied to the outside of the reservoir to prevent sweating and heat gain. Reservoirs used in 2-pump systems include a baffle that provides hot/cold service.

Polyethylene... The **TOUGH TANK**[®] is a cylindrical, seamless, one piece tank, rotational molded from linear low density polyethylene. Rust and corrosion free, **TOUGH TANK**[®] will not degrade regardless of water quality. The baffle provides hot / cold water service. Pump assemblies are mounted on a structural steel deck and attached to the tank via flexible connectors. The rectangular base offers greater stability and the ability to expand capacity by in-line plumbing of additional tanks and pumps. A tank lid is included. A 10 year tank failure warranty is standard with systems using the Tough Tank[™] reservoir.

Mild & Stainless Steel... 10 gauge stainless or 7 gauge mild steel sheets are welded into form with perimeter belting to increase strength. Wetted surfaces on mild steel tanks receive a thick layer of 2 part epoxy coating. A partition is set inside the tank to serve as a hot and cold section divider. The tank assembly is set onto a structural steel base. The base area not immediately underneath the tank is decked with sheet metal and becomes the pump platform.

OPTIONAL FEATURES AVAILABLE TO CUSTOMIZE YOUR SYSTEM

VARIABLE SPEED DRIVES...

Save money by always using only the pumping energy necessary for your system by installing a variable speed drive on your process pump. A variable speed drive system adjusts the process flow rate to meet the ever changing needs of your system. A 20% reduction in flow can equal nearly a 50% reduction in pumping energy.



STANDBY PUMP & MANIFOLD...

Prewired standby pumps and preplumbed manifolds are offered for process, tower or evaporator pumps. This feature assures uninterrupted operation when service is required on the primary pump but continued operation is necessary. Costs are higher for systems that must have field supplied manifolds, compared to systems with factory supplied manifolds.



SPACE SAVING SYSTEMS...

The **Tough Tank**[®] reservoir is set on top of the pumping system to save floor space. Many pump configurations, from single, dual and standby pumps with manifolds are designed to occupy space underneath the tank.

CONTROL SYSTEMS

All Advantage pump tank systems include controls appropriate for a complete and workable system. Controls from basic manual push button motor starters and thermostats to advanced programmable logic controllers (PLC) with touch screen interface are available.

All systems include pump motor starters with motor protection. Cooling tower systems include fan motor starters and staging thermostats.

Most systems with tower fans, tower pumps and alarms use the CheckMate™ control and monitoring system or a multistage electronic temperature control thermostat.



MULTISTAGE CONTROLLER... stages tower fans and tower pumps to match system capacity to the cooling load. This panel mounted control package maintains a consistent water temperature regardless of load and ambient conditions. The electronic thermostat features a digital set point and a digital readout of actual water temperature. A single set point value is entered and offsets stage fans, pumps and alarms are staged appropriately... no need to set individual thermostats.

OPTIONAL CHECKMATE™ COOLING TOWER SYSTEM CONTROL AND MONITORING INSTRUMENT... this exclusive Advantage feature displays performance, status of all motors, alarms and temperatures. The CheckMate™ display panel works in conjunction with the CheckMate™ staging board to stage pumps and fans to match system capacity to current load. Up to six temperatures can be displayed at the "Temperature Status" screen including to process, from process, tower in and tower out (on evaporative cooling tower systems). Additional information is accessed on display screens for "Water Status", "Set Up", "Error Log" and "Accumulated Run Time".

Exclusive Top Operator™ switches provide motor and overall system control. A main power on/off switch engages power to the system. An emergency stop button kills power to all motors if required. Process and evaporator (on chilled water systems) pumps are activated with an on/off switch with integral LED light that is green when the pump is running and red if the pump is off due to an overload condition. Tower pumps and fans (on evaporative cooling tower systems) use on/off/auto switches. When placed in the auto position, the CheckMate™ temperature control board stages the pump(s) and fan(s) to match system capacity to cooling requirements in order to maintain consistent water temperature. When placed in the "on" position, the pump or fan motor will run continuously.



When more than 6 pumps (3 process & 3 staged tower pumps) or more than 4 fan stages are required on a system, individual motor lights and operators along with an independent digital temperature readout often replaces the CheckMate™ system controller to provide a clearer operator interface. This operator interface may also be used when certain options are selected such as variable speed drive packages.

When systems require advanced control or plant wide integration, an advanced PLC with customized programming can be provided.

PUMPS

Advantage provides high efficiency centrifugal pump and motor assemblies from recognized leaders in their field. Careful consideration to service, efficiency and motor protection are central to the design and selection of the best pump for your application. All pumps include full pump trim including suction and discharge service valves. Schedule 80 PVC or welded steel pump trim may be used depending on pipe size and duty.

Nominal pump flow rates are 2.4 gallons per minute per ton for chilled water systems and 3 gallons per minute for cooling tower systems. Process pumps are selected to provide approximately 45 to 60 pounds per square inch of pressure while recirculating pumps produce 25 to 30 pounds per square inch. Where higher flow rates or higher system pressure is required appropriate pump selections are made by our experienced application engineers.



Phone: 317-887-0729 Web: www.AdvantageEngineering.com



CENTRAL CONTROL CONSOLE... Provides easier and less costly installation and operator convenience. Includes a Nema 12 cabinet, seal tight conduit, branch circuit fusing, control transformer and single power connection. 'Power On' light and off/on selector switches are mounted on the cabinet exterior. This option is required when selecting the CheckMate™ cooling tower system control and monitoring Instrument.



TEMPERATURE AND PRESSURE ALARM SYSTEM... Pump pressure and fluid temperatures are constantly monitored. A pressure switch is mounted in the process pump discharge stream and a thermostat monitors water temperature in the tank. An out-of-spec condition will activate the audible and visual alarm.

ELECTRIC WATER LEVEL CONTROL... A float switch activates a solenoid valve to feed water to the tank. The float is mounted in a small enclosed tank positioned at the proper operating water level external to the main reservoir. The water inside the float tank is not subject to turbulence that may exist inside the main tank. Water level can be visually sighted by the clear sight tube on Tough Tank® reservoirs.



SPECIFICATIONS

MODEL		TTK-450	TTK-850	TTK-1600	TTK-3200	TTK-450-SS	TTK-850-SS	TTK-1600-SS	TTK-3200-SS
Water Capacity (gallons)	To Overflow	450	850	1600	3,200	450	850	1,600	3,200
	Normal Operating (Tower)	255	425	800	1,600	255	425	840	1,600
	Normal Operating (Chiller)	350	675	1,200	2,400	350	675	1,200	2,400
Reservoir	Type ¹	PE	PE	PE	PE	PE	PE	PE	PE
Connection Sizes (inches)	Water Make-Up	1	1	1	1	1	1	1	1
	Tank Drain	1½	1½	1½	1½	1½	1½	1½	1½
	Tank Overflow	4	4	6	6	4	4	6	6
Dimensions (inches)	Height	60	72	96	96	60	120	144	144
	Width	48	62	75	160	48	66	78	160
	Depth (tank only)	50	62	75	75	50	68	80	80
	Depth (tank - 2 Pump)	100	116	130	130	n/a	n/a	n/a	n/a
	Depth (tank - 3 Pump)	109	124	138	138	n/a	n/a	n/a	n/a
Weights (LBS)	Dry	860	1,590	2,243	4,636	2,100	3,390	4,493	9,136
	Maximum	4,640	8,730	15,525	31,516	5,880	10,530	17,935	36,016
	Shipping ⁴	860	1,590	2,243	4,636	2,100	3,390	4,473	9,136

MODEL PTS-CPTS ³		PTS-275	PTS-400	PTS-600	PTS-750	PTS-1000	PTS-1250	PTS-1500	PTS-2000	PTS-2500	PTS-3000
Water Capacity (gallons)	To Overflow	275	400	600	750	1,000	1,250	1,500	2,000	2,500	3,000
	Normal Operating (Tower)	180	240	345	450	560	700	840	1,120	1,875	1,625
	Normal Operating (Chiller)	180	300	485	615	790	985	1,185	1,575	1,400	2,35
Reservoir	Type ¹	ST	ST	ST	ST	ST	ST	ST	ST	ST	ST
Connection Sizes (inches)	Water Make-Up	1	1	1	1	1	1¼	1¼	1¼	1¼	1¼
	Tank Drain	1½	1½	1½	1½	1½	1½	1½	1½	1½	1½
	Tank Overflow	4	4	4	4	4	4	4	4	6	6
Dimensions (inches)	Height	55	55	67	79	79	79	79	79	79	79
	Width	60	60	72	72	72	72	72	72	72	144
	Depth (tank)	24	36	36	36	48	60	72	72	120	72
	Depth (total)	60	72	80	80	100	112	112	112	174	124
Weights (LBS)	Dry	1,625	1,745	2,300	2,800	3,250	4,300	4,500	4,500	8,480	6,580
	Maximum	3,915	5,075	7,295	9,050	11,580	14,715	17,000	17,000	26,300	31,600
	Shipping ⁴	1,725	1,845	2,400	2,920	3,370	4,500	4,700	4,700	5,700	6,750

Process Pump		PP-2	PP-3	PP-5	PP-7.5	PP-10	PP-15	PP-20	PP-25	PP-30	PP-40	PP-50	PP-60
Pump	HP	2	3	5	7.5	10	15	20	25	30	40	50	60
	GPM ²	40	60	90	150	210	360	405	525	600	900	1,100	1,250
	PSI ²	40	60	60	60	60	60	60	60	60	60	60	60
Unit Amperage (Full Load) @3ø/60hz	230 Volts	6.8	9.6	15.2	22.0	28.0	42.0	54.0	68.0	84.0	104.0	130.	154.0
	460 Volts	3.4	4.8	7.6	11.0	14.0	21.0	27.0	34.0	42.0	52.0	65.0	77.0
	575 Volts	2.7	3.9	6.1	9.0	11.0	17.0	22.0	27.0	32.0	41.0	52.0	62.0

Tower/Evaporator Pump		TP-2	TP-3	TP-5	TP-7.5	TP-10	TP-15	TP-20	TP-25	TP-30	TP-40
Pump	HP	2	3	5	5	10	15	20	25	30	40
	GPM ²	60	90	210	255	405	525	810	900	1,100	1,750
	PSI ²	30	30	30	30	30	30	30	30	30	30
Unit Amperage (Full Load) @3ø/60hz	230 Volts	6.8	9.6	15.2	22.0	28.0	42.0	54.0	68.0	84.0	104.0
	460 Volts	3.4	4.8	7.6	11.0	14.0	21.0	27.0	34.0	42.0	52.0
	575 Volts	2.7	3.9	6.1	9.0	11.0	17.0	22.0	27.0	32.0	41.0

Stanby Pump		SP-2	SP-3	SP-5	SP-7.5	SP-10	SP-15	SP-20	SP-25	SP-30	SP-40	SP-50	SP-60
Pump	HP	2	3	5	7.5	10	15	20	25	30	40	50	60
	GPM ²	40	60	90	150	210	360	405	525	600	900	1,100	1,250
	PSI ²	40	80	60	60	60	60	60	60	60	60	60	60
Unit Amperage (Full Load) @3ø/60hz	230 Volts	6.8	9.6	15.2	22.0	28.0	42.0	54.0	68.0	84.0	104.0	130.	154.0
	460 Volts	3.4	4.8	7.6	11.0	14.0	21.0	27.0	34.0	42.0	52.0	65.0	77.0
	575 Volts	2.7	3.9	6.1	9.0	11.0	17.0	22.0	27.0	32.0	41.0	52.0	62.0

Notes: 1. PE = Polyethylene reservoir, 115°F maximum continuous water temperature; ST = steel reservoir. 2. Approximate flow and pressure. 3. PTS - uninsulated steel or stainless steel tank; CPTS insulated steel or stainless steel tank. 4. Estimated shipping weight subject to change based on pump configurations and options selected.

OTHER PRODUCTS



Phone: 317-887-0729 Web: www.AdvantageEngineering.com

TEMPERATURE CONTROLLERS • PORTABLE CHILLERS • CENTRAL CHILLERS • PUMP TANK STATIONS • TOWER SYSTEMS • FILTERS

ADVANTAGE ENGINEERING, INC. 525 East Stop 18 Road Greenwood, IN 46142 phone: 317-887-0729 fax: 317-881-1277
 web site: www.AdvantageEngineering.com email: sales@AdvantageEngineering.com ©2007 ADVANTAGE ENGINEERING, INC. Form #ADV-615 8/07

SINCE PRODUCT INNOVATION AND IMPROVEMENT IS OUR CONSTANT GOAL, ALL FEATURES AND SPECIFICATIONS ARE SUBJECT TO CHANGE WITHOUT NOTICE OR LIABILITY.